

Intake Exhaust Vent Installation Instructions

-To be installed prior to siding-

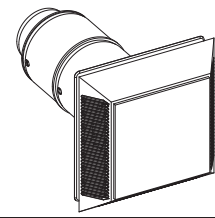

Step 1

Remove the Cap from the Vent assembly by turning the Cap counter clockwise. Place tape or sealant between the Intake Exhaust Vent and house. Align the tube with the available opening (Suggested hole size: 4 1/8" diameter.) See Figure 1 at right.

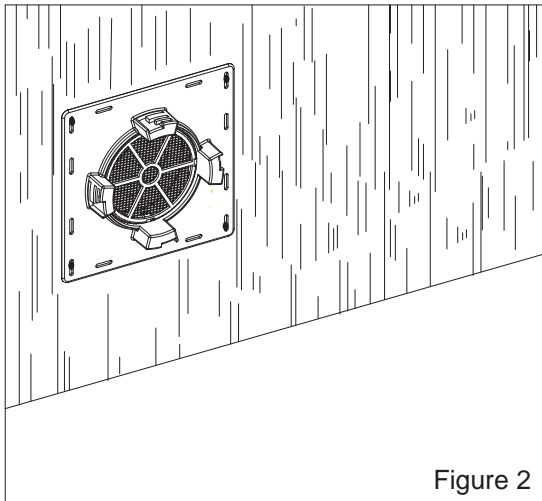
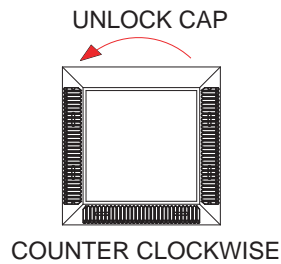
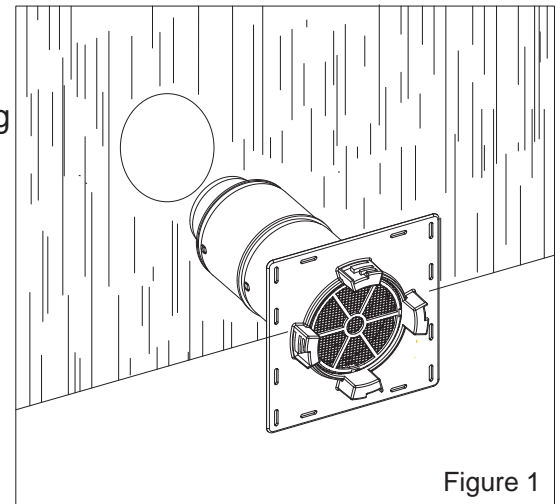

Step 2

Attach the Intake Exhaust Vent using an 8d nail or equivalent with a minimum of four attachments. See Figure 2 at left.

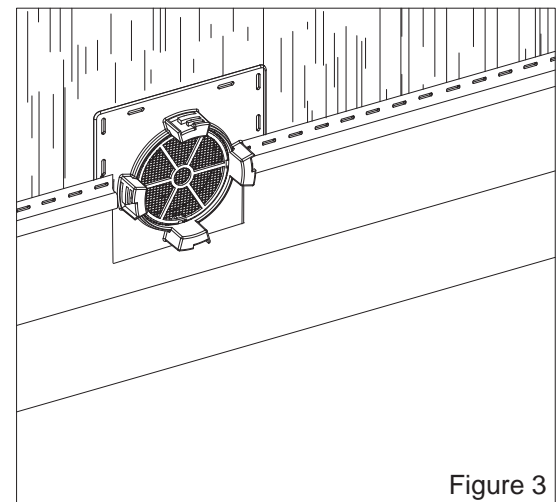

Step 3

Once the Intake Exhaust Vent has been securely fastened, cut the siding around the vent. Install the siding according to the manufacturer's installation instructions. See Figure 3 at right.

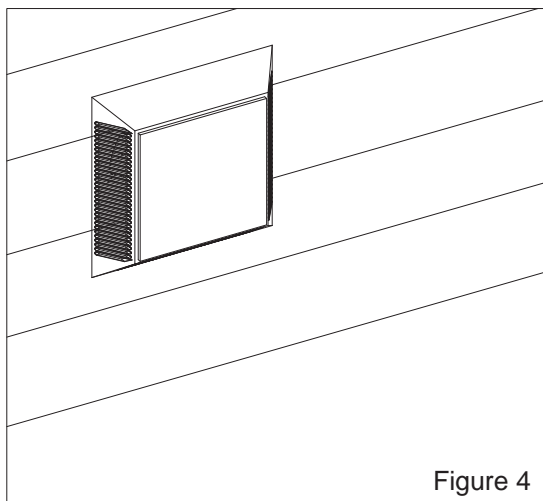

Step 4

Lock on the Intake Exhaust Vent Cap. See Figure 4 at left.

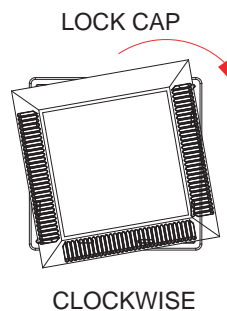

ENGAGE LOCKING TABS
INTO LOCKING SLOTS

